

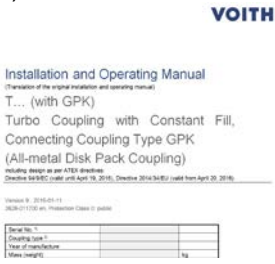

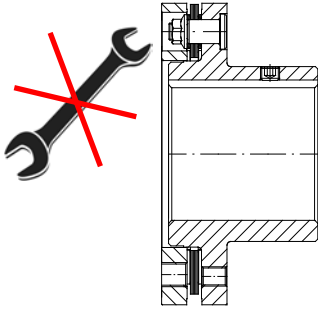

Quick Guide for Installation **GPK, design without clamping hub** 91800234010

Note:

This guide is **not** intended to replace the installation and operating manual. It just illustrates steps required during installation of a **GPK** type connecting coupling and provides reference to the installation and operating manual for full details.

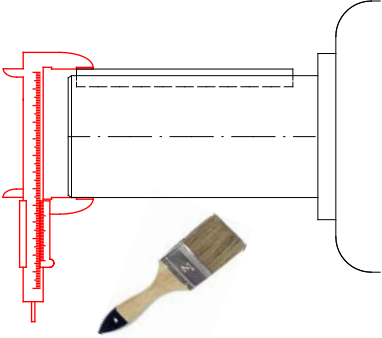
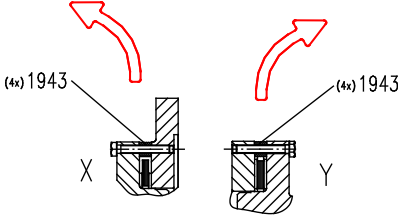
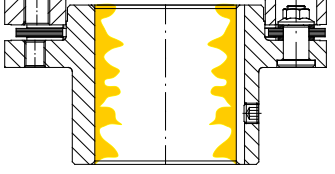
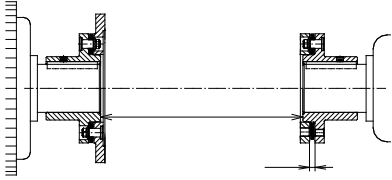
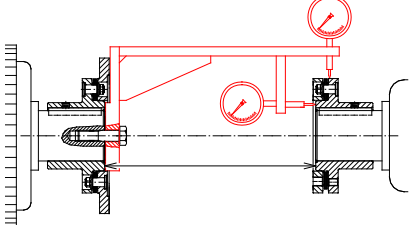
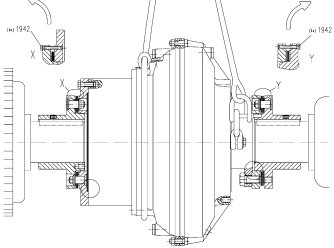
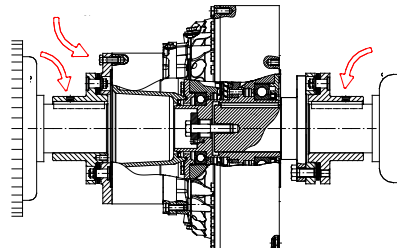
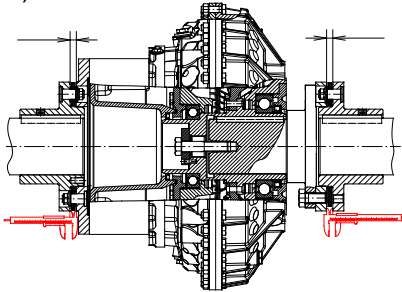
<p>1)</p>  <p>Read and observe the latest version of the Manual 3626-011700 before starting to work.</p>	<p>2)</p>  <p>Do not remove the disk packs from the hubs!</p>	<p>3)</p>  <p>Have ready the required tools (see Chapter 8.2).</p>
<p>4)</p>  <p>Check and prepare the shafts and hubs for mounting: apply lubricant (see Chapter 8.3).</p>	<p>5)</p>  <p>Remove the spacer sleeves and warning labels (see Chapter 8.5).</p>	<p>6)</p>  <p>max. 150 °C (302 °F) Recommendation: Warm up the hubs evenly to 80 °C (176 °F).</p> <p>Mount the input and output hub (see Chapters 8.4, 8.5).</p>
<p>7)</p>  <p>Set the hub gap (see Chapter 8.5.2.1).</p>	<p>8)</p>  <p>Align the shafts (see Chapters 8.5.2.2, 8.5.2.3).</p>	<p>9)</p>  <p>Install the turbo coupling (see Chapter 8.5.3).</p>
<p>10)</p>  <p>Tighten the connection coupling screws (see Chapter 7).</p>	<p>11)</p>  <p>Check the alignment (see Chapter 8.5.4).</p>	<p>12)</p> <p>Fill in the specified quantity of operating fluid:</p>  <p>(see Chapter 9 and 10).</p>